



# COMPATIBILITY OF CASSETTE BODIES 2013



# COMPATIBILITY OF CASSETTE BODIES

## NEW COMPATIBILITIES



## OLD COMPATIBILITIES



Inner diameter of cassette body is refer to the axle Ø.



D/ Cassette Body with 2 Sealed Bearings  
E/ Special Design with 2 Sealed Bearings and 1 Needle Bearing

## SIDE CAPS

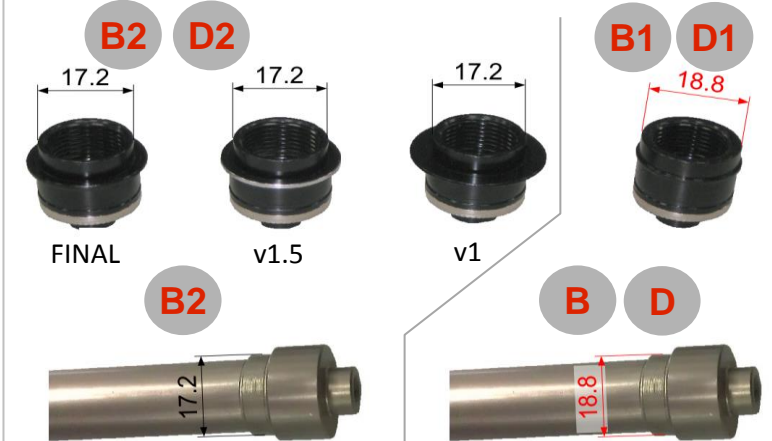

## SHIMANO SEALS



## COMPATIBILITY OF CASSETTE BODIES

**A** **A2** 2 Sealed Bearings, Small Axle Diameter ( $\varnothing 12\text{mm}$ ), Material of Axle Can be CrMo or Alloy.

**C** **E** **C2** 2 Sealed Bearings + 1 Needle Bearing, Small Axle Diameter, Material of Axle Must be CrMo.

**B** **B1** **B2** 2 Sealed Bearings, Wide Axle Diameter ( $\varnothing 15\text{mm}$ ), Material of Axle Can be CrMo or Alloy.  
B, B1 are the Same but Using Different Seal in Side Cap Side.

**D** **D1** **D2** D, D1 are the Same but Using Different Seal in Side Cap Side.

**A2** **B2** **D2** **C2** A2, B2, D2, C2 are Shim. 11 speed compatible

**X4** **XS** 2 Sealed Bearings, Wide Axle Diameter ( $\varnothing 15\text{mm}$ ), Material of Axle is Alloy.  
Cassette body has 6 pawls working in offset. Ratchet ring has 42 teeth.  
X4 cassette bodies are using exclusively for Novatec MTB wheels published in catalog 2013  
XS cassette body is using for Novatec MTB Synergy Cantilever hub published in catalog 2013



SRAM XD



**CATALOGS 2013 (selling during year 2013)**

| NOVATEC WHEELS           |          | HAVE TO CHANGE   |   |
|--------------------------|----------|--|---|
| MODEL                    | TYPE     |  |   |
| R1_u1.0/u1.1             | D2       | From Shim. to Campy change only cassette body, other parts are not required to be changed. |   |
| R3_u1.0/u1.1             | D2       |  |   |
| R5_u1.0/u1.1             | D2       |  |   |
| R9_u1.0/u1.1             | D2       |  |   |
| JETFLY_u1.0/u1.1         | D2 (*D1) |  |   |
| SPRINT_u1.0/u1.1         | D2 (*D1) |  |   |
| IMPULSE_u1.0/u1.1        | D2       |  |   |
| CXD_u1.0/u1.1            | D2 (*D1) |  |   |
| DRAGON_u1.0/u1.1         | X4 (*B1) |  | If you want to convert MTB wheels from year 2013 to Sram XD you're going to need NEW AXLE. Original axle on rear hub works only with Shim |
| FLOWTRAIL_u1.0/u1.1      | X4 (*B1) |  |   |
| DIABLO_u1.0/u1.1         | X4 (*B1) |  |   |
| DEMON_u1.0/u1.1          | X4 (*B1) |  |   |
| DRAGON 29_u1.0/u1.1      | X4       |  |   |
| FLOWTRAIL 29_u1.0/u1.1   | X4       |  |   |
| DIABLO 29_u1.0/u1.1      | X4       |  |   |
| DEMON 29_u1.0/u1.1       | X4       |  |   |
| FLOWTRAIL 27.5_u1.0/u1.1 | X4       |  |   |
| DIABLO 27.5_u1.0/u1.1    | X4       |  |   |

| ROAD NOVATEC HUBS |          |                 | HAVE TO CHANGE  |
|-------------------|----------|-----------------|-----------------|
| MODEL             | TYPE     | SYSTEM          |                 |
| F282CB            | A2 (*A)  | Shim./Sram      | Washer position |
| F382CB            | A2 (*A)  | Campy           | Washer position |
| F282SB            | A2 (*A)  | Shim./Sram      | Washer position |
| F382SB            | A2 (*A)  | Campy           | Washer position |
| FS12CB            | A2 (*A)  | Shim./Sram      | Washer position |
| FS22CB            | A2 (*A)  | Campy           | Washer position |
| FS12SB            | A2 (*A)  | Shim./Sram      | Washer position |
| FS22SB            | A2 (*A)  | Campy           | Washer position |
| F682SB            | B2 (*B1) | Shim./Sram      | Washer position |
| F782SB            | B2 (*B1) | Campy           | Washer position |
| F292CB            | C2 (*C)  | Shim./Sram      | Washer position |
| F392CB            | C2 (*C)  | Campy           | Washer position |
| F482SB            | B2 (*B1) | Shim./Sram      | Washer position |
| F582SB            | B2 (*B1) | Campy           | Washer position |
| F482SB-SL         | B2 (*B1) | Shim./Sram      | Washer position |
| F582SB-SL         | B2 (*B1) | Campy           | Washer position |
| F162SB            | A2 (*A)  | Shim./Sram      | Washer position |
| F262SB            | A2 (*A)  | Campy           | Washer position |
| F372SB            | A2 (*A)  | Shim./Sram      | Washer position |
| F472SB            | A2 (*A)  | Campy           | Washer position |
| F172SB            | A2 (*A)  | Shim./Sram      | Washer position |
| F272SB            | A2 (*A)  | Campy           | Washer position |
| D722SB            | B2 (*B1) | Shim./Sram      | Washer position |
| D732SB            | B2 (*B1) | Campy           | Washer position |
| D352SB            | A2 (*A)  | Shim./Sram      | Washer position |
| D452SB            | A2 (*A)  | Campy           | Washer position |
| D632SB            | A2 (*A)  | Shim./Sram      | Washer position |
| D642SB            | A2 (*A)  | Campy           | Washer position |
| F422SB            | S3       | Shim./Sram only |                 |
| F022SB            | S2       | Shim./Sram only |                 |
| F192SB            | S1       | Shim./Sram only |                 |
| F472SBT           | F472SBT  | Campy only      |                 |
| F422GCC           | G3       | Shim./Sram only |                 |
| F192GCC           | G1       | Shim./Sram only |                 |
| F032GCC           | F032GCC  | Campy only      |                 |
| F192GCC           | G1       | Shim./Sram only |                 |
| F032GCC           | F032GCC  | Campy only      |                 |

| MTB NOVATEC HUBS |          |            | HAVE TO CHANGE |
|------------------|----------|------------|----------------|
| MODEL            | TYPE     | SYSTEM     |                |
| D542SB           | XS       | Shim./Sram |                |
| DS52SB           | B2 (*B1) | Shim./Sram |                |
| DS12SB           | A2 (*A)  | Shim./Sram |                |
| D612SB           | B2 (*B1) | Shim./Sram | Right side cap |
| D622SB           | B2 (*B1) | Campy      |                |
| D712SB           | B2 (*B1) | Shim./Sram | Right side cap |
| D702SB           | B2 (*B1) | Campy      |                |
| D812SB           | A2 (*A)  | Shim./Sram |                |
| D042SB           | A2 (*A)  | Shim./Sram |                |
| D142SBT          | S1       | Shim./Sram |                |
| D522SB           | S3       | Shim./Sram |                |
| D522GCC          | G3       | Shim./Sram |                |
| D342GCC          | G1       | Shim./Sram |                |
| F742SB           | B2 (*B1) | Shim./Sram | Right side cap |
| F842SB           | B2 (*B1) | Campy      |                |
| F062SB           | A        | Shim./Sram |                |
| F522SB           | S3       | Shim./Sram |                |
| 802SB            | S1       | Shim./Sram |                |
| F522GCC          | G3       | Shim./Sram |                |
| 802GCC           | G1       | Shim./Sram |                |
| D992SB           | B2 (*B)  | Shim./Sram |                |
| D882SB           | B2 (*B)  | Shim./Sram |                |
| DH82SB           | B2 (*B)  | Shim./Sram |                |
| DH12SB           | B2 (*B)  | Shim./Sram |                |
| D362SB           | B2 (*B)  | Shim./Sram |                |
| D142SB-X12       | S5       | Shim./Sram |                |
| D142SB-10        | S4       | Shim./Sram |                |

\* Cassette body type published in catalog 2012  
 \*\* A2 type = A type